

BALLISTIC RESISTANT HIGH SECURITY STEEL DOOR MODEL 769

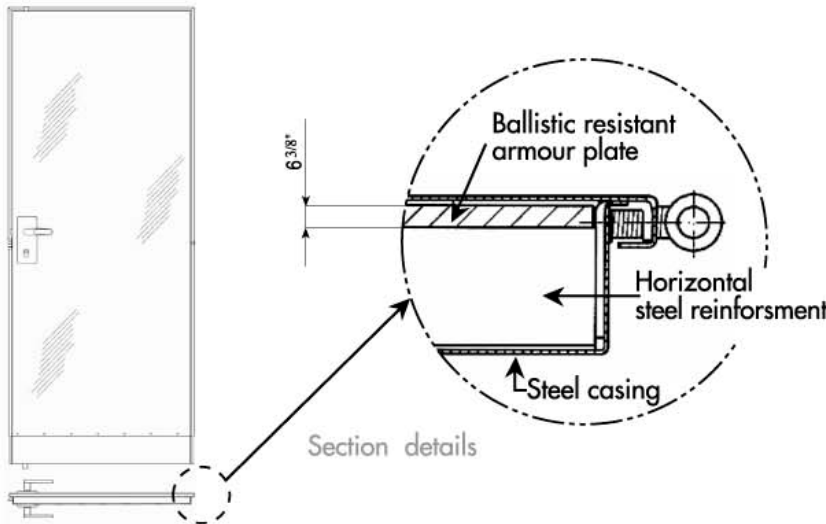

The ballistic resistant door is a complete protective system for the entrance of heavily secured areas.

Construction is of reinforced steel with a high security 4 - way lock, ballistic resistant elements (bullet resistant window is optional) and various accessories.



Construction frame

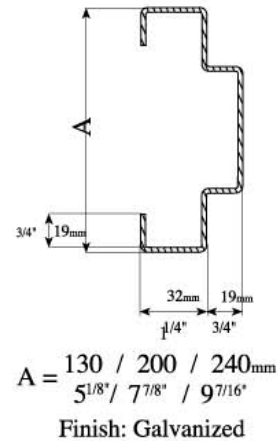

Approval:

1. Ballistic resistant armour steel plate, tested according to U.L. 752 protection level 4.
2. Ballistic resistant transparency, tested according to DIN 52290 part 2, using an AK-47 rifle.

Structure:

The Steel Door is made of two 1.25mm (18 gauge) thick galvanized steel casings, which are reinforced by horizontal steel bars, placed between the casings and the armour plate.

Ballistic resistant armour plate:

U.L. 752 level 4 approved. The armour plate extends 50mm (2") into the bottom insert.

Door weight :

The standard door leaf weighs approximately 130 Kg (286 lb).

Door dimensions:

Door height without lower insert

Range of coverage scope in height

Door width

Door height without lower insert		Range of coverage scope in height		
		Min size	Max size	
1685mm	66 ⁵ / ₁₆ "	1715mm	67 ¹ / ₂ "	
1785mm	70 ¹ / ₄ "	1815mm	71 ⁷ / ₁₆ "	
1885mm	74 ³ / ₁₆ "	1915mm	75 ³ / ₈ "	
1910mm	75 ³ / ₁₆ "	1940mm	76 ³ / ₈ "	
1985mm	78 ¹ / ₈ "	2015mm	79 ⁵ / ₁₆ "	
2085mm	82 ¹ / ₁₆ "	2115mm	83 ¹ / ₄ "	
2185mm	86"	2215mm	87 ³ / ₁₆ "	
2285mm	89 ¹⁵ / ₁₆ "	2315mm	91 ¹ / ₈ "	
			1810mm	71 ¹ / ₄ "
			1910mm	75 ³ / ₁₆ "
			2000mm	78 ³ / ₄ "
			2040mm	80 ⁵ / ₁₆ "
			2110mm	83 ¹ / ₁₆ "
			2210mm	87"
			2310mm	90 ¹⁵ / ₁₆ "
			2410mm	94 ⁷ / ₈ "

The door leaf is supplied in a variety of widths, in increments of 20mm (13/16")
Min - 300mm (11¹³/₁₆") Max - 1080mm (42¹/₂")

Double door :

A combination of two available width sizes.

Frame:

Construction frame only, due to door's weight.

Accessories & Hardware :

MUL-T-LOCK 4 - way lock model 265, High Security MUL-T-LOCK cylinder, double cylinder protector, floor door stopper, security covers and handles.

